

Cyclone Rake[®] XL

JetPath[®]
VACUUM SYSTEM

APPLICATION AND USE:

The Cyclone Rake XL delivers commercial power for large properties, estates, condos, schools, commercial use and properties with very heavy leaf cover. A 14 HP or larger tractor is recommended for this Cyclone Rake model. For properties with slopes and gradients, a tractor size of 16 HP or larger is recommended.

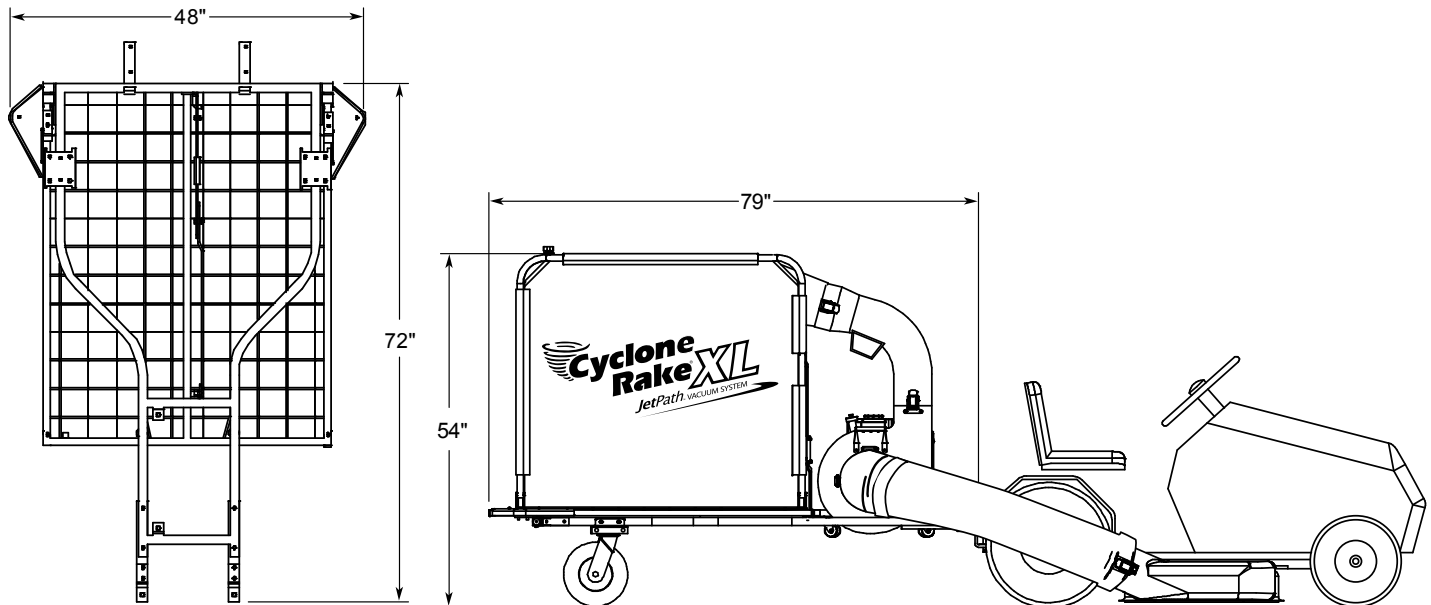

As folded flat,
for wall mounting.

Side elevation view

Product Specifications		Accessories Available	
Vacuum system	8-inch Diameter — JetPath [®]	32 ft. Estate Vacuum	Yes
Engine	8 HP B&S Vanguard 13.4 ft. lbs. of torque	17 ft. Power Vacuum Pickup	Yes
Capacity	415 gal. • 55 cu. ft. • 44 bushels	Power Bagger	Yes
Impeller	Super-Flow — 5-blade	Roof Rack Carrier	Yes
Unloading method	Easy-Flow	Power Unloader	Yes
W x H x L	48" x 54" x 79"	Wall Mount Kit	Yes
Collector dumping angle	60°	3rd Wheel Jack Stand	Yes
Rigid dumping lock	Yes	Mower Deck Adapter (MDA)	Yes
Hitch type	2 Pin: Never jackknifes	Cyclone Master Power Lifter	Yes
Folds flat for storage	Yes	Cyclone Mate Power Lifter	Yes
Mower or Tractor Requirements		Weather Defender Outdoor Cover	Yes
Mower or tractor required	14 HP or larger. Front engine or ZTR.	PRO Upgrades Available	
Mower deck requirement	Right-side discharge	Tuff-PRO Super Hose	Included
		Dual-PRO Super Wheels	Yes
		Blue Diamond Liner	Yes

WOODLAND POWER PRODUCTS, INC.

72 Acton Street, West Haven, Connecticut 06516

www.CycloneRake.com

©2010, Woodland Power Products, Inc.

TOLL-FREE 1-(888)-531-RAKE

01-06-094 F11