

# Cyclone Rake<sup>®</sup> XL

**JetPath<sup>®</sup>**  
VACUUM SYSTEM

## APPLICATION AND USE:

The Cyclone Rake XL delivers commercial power for large properties, estates, condos, schools, commercial use and properties with very heavy leaf cover. A 14 HP or larger tractor is recommended for this Cyclone Rake model. For properties with slopes and gradients, a tractor size of 16 HP or larger is recommended.

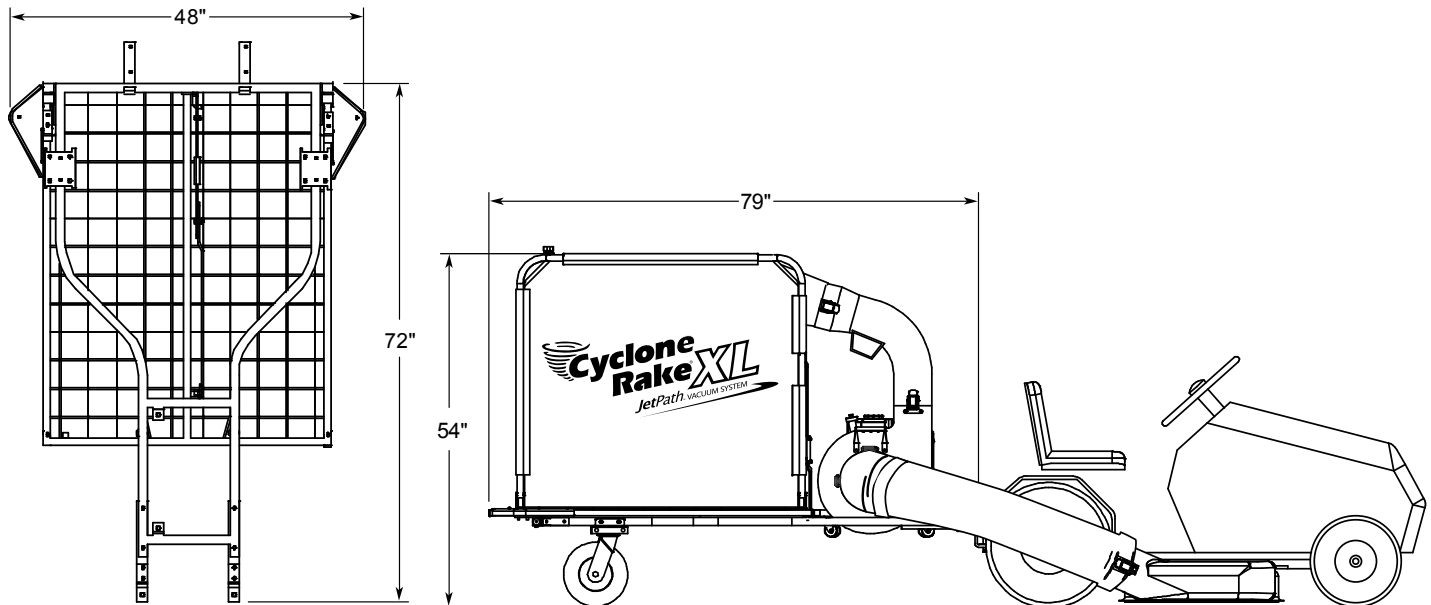

As folded flat,  
for wall mounting.

Side elevation view

Product Specifications		Accessories Available	
Capacity	415 gal. • 55 cu.ft. • 44 bushels	32 ft. Estate Vacuum	Yes
W x H x L	48" x 54" x 79"	17 ft. Power Vacuum Pickup	Yes
Engine	9 HP OHV B&S Vanguard 13.4 ft. lbs. of torque	Power Bagger	Yes
Vacuum system	<b>JetPath</b>	Roof Rack Carrier	Yes
Deck hose size	8-inch diameter	Power Unloader	Yes
Miracle Impeller	5-blade Super-Flow	Wall Mount Kit	Yes
Easy-Flow™ unloading	Yes	3rd Wheel Jack Stand	Yes
Collector dumping angle	60°	Mower Deck Adapter (MDA)	Yes
Rigid dumping lock	Yes	Cyclone Master Power Lifter	Yes
Hitch type	Never jackknives	Cyclone Mate Power Lifter	Yes
Folds flat for storage	Yes	Weather Defender Outdoor Cover	Yes
Mower or Tractor Requirements		PRO Upgrades Available	
Mower or tractor required	14 HP or larger. Front engine or ZTR.	Tuff-PRO Super Hose	Included
Mower deck requirement	Right-side discharge	Dual-PRO Super Wheels	Yes
		Blue Diamond Liner	Yes

**WOODLAND POWER PRODUCTS, INC.**

72 Acton Street, West Haven, Connecticut 06516

www.CycloneRake.com

©2009, Woodland Power Products, Inc.

**TOLL-FREE 1-(888)-531-RAKE**

01-06-094 F09