

### APPLICATION AND USE:

The Cyclone Rake Commercial PRO delivers heavy-duty power for large properties with heavy leaf cover and extensive lawns. A 14 HP or larger tractor is recommended for this Cyclone Rake model. For properties with slopes and gradients, a tractor size of 16 HP or larger is recommended.

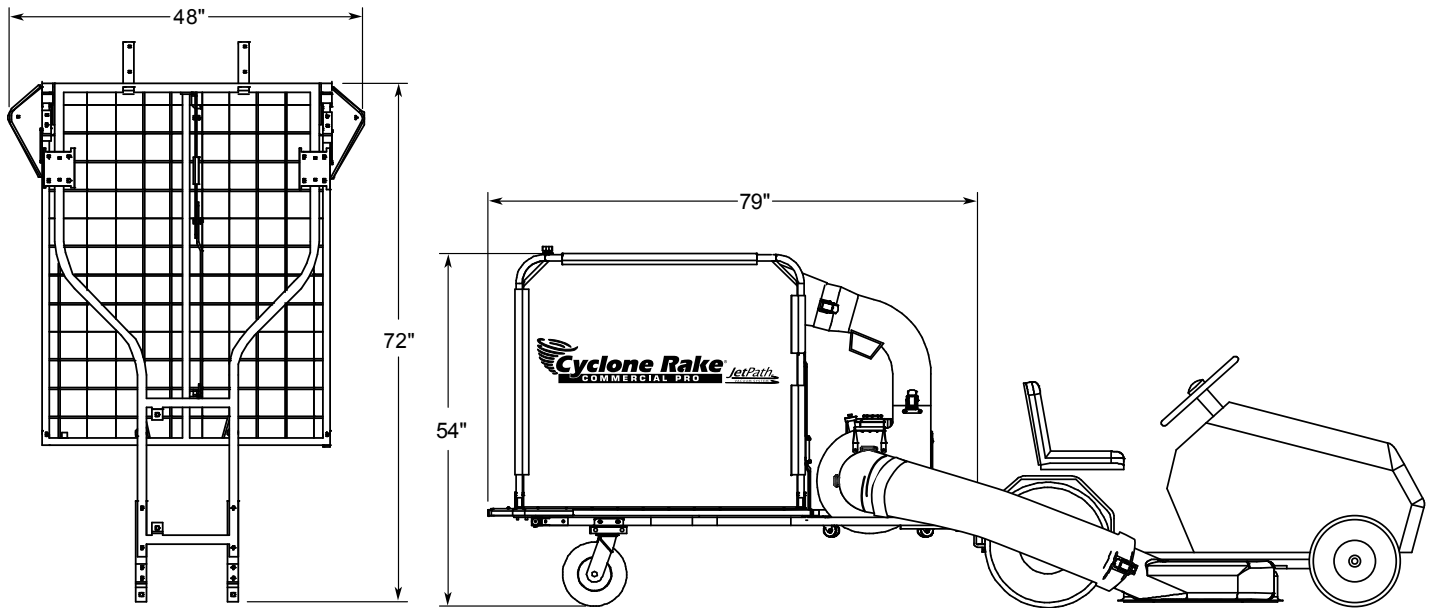

As folded flat,  
for wall mounting.

Side elevation view

Product Specifications	
Capacity	415 gal. • 55 cu.ft. • 44 bushels
W x H x L	48" x 54" x 79"
Engine	6.5 HP OHV B&S Vanguard 9.1 ft. lbs. of torque
Vacuum system	<b>JetPath</b>
Deck hose size	8-inch diameter
Miracle Impeller	5-blade Hi-Flow
Easy-Flow™ unloading	Yes
Collector dumping angle	60°
Rigid dumping lock	Yes
Hitch type	Never jackknives
Folds flat for storage	Yes
Mower or Tractor Requirements	
Mower or tractor required	14 HP or larger. Front engine or ZTR.
Mower deck requirement	Right-side discharge

Accessories Available	
32 ft. Estate Vacuum	Yes
17 ft. Power Vacuum Pickup	Yes
Power Bagger	Yes
Roof Rack Carrier	Yes
Power Unloader	Yes
Wall Mount Kit	Yes
3rd Wheel Jack Stand	Yes
Mower Deck Adapter (MDA)	Yes
Cyclone Master Power Lifter	Yes
Cyclone Mate Power Lifter	Yes
Weather Defender Outdoor Cover	Yes
PRO Upgrades Available	
Tuff-PRO Super Hose	Yes
Dual-PRO Super Wheels	Yes
Blue Diamond Liner	Yes