

APPLICATION AND USE:

The Cyclone Rake Commander is the perfect combination of power and performance for average sized properties with moderate to heavy leaf cover. A 10 HP or larger tractor is recommended for this Cyclone Rake model. For properties with slopes and gradients, a tractor size of 14 HP or larger is recommended.

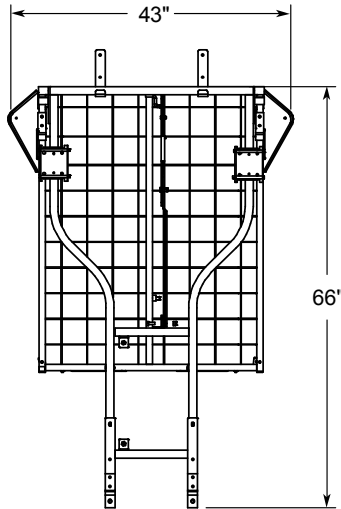

As folded flat,
for wall mounting.

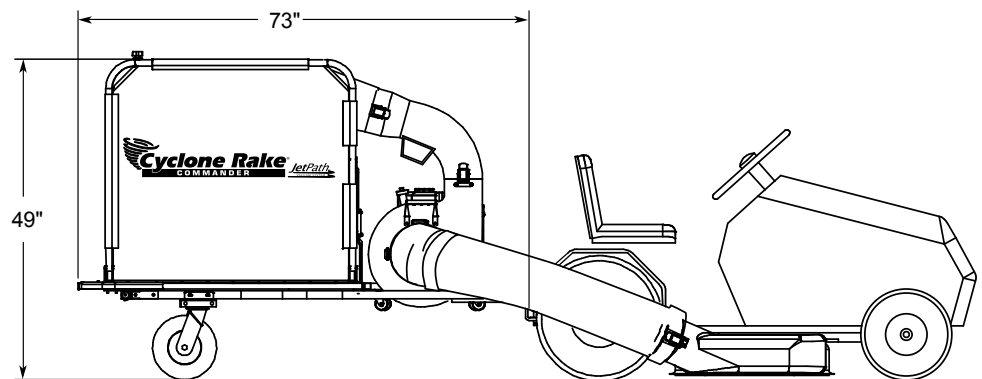

Side elevation view

Product Specifications		Accessories Available	
Capacity	285 gal. • 38 cu.ft. • 32 bushels	32 ft. Estate Vacuum	Yes
W x H x L	43" x 49" x 73"	17 ft. Power Vacuum Pickup	Yes
Engine	6.5 HP OHV B&S Vanguard 9.1 ft. lbs. of torque	Power Bagger	Yes
Vacuum system	JetPath	Roof Rack Carrier	Yes
Deck hose size	8-inch diameter	Power Unloader	Yes
Miracle Impeller	4-blade heavy duty	Wall Mount Kit	Yes
Easy-Flow™ unloading	yes	3rd Wheel Jack Stand	Yes
Collector dumping angle	60°	Mower Deck Adapter (MDA)	Yes
Rigid dumping lock	Yes	Cyclone Master Power Lifter	Yes
Hitch type	Never jackknives	Cyclone Mate Power Lifter	Yes
Folds flat for storage	Yes	Weather Defender Outdoor Cover	Yes
Mower or Tractor Requirements		PRO Upgrades Available	
Mower or tractor required	10 HP or larger. Rear or front engine or ZTR.	Tuff-PRO Super Hose	Yes
Mower deck requirement	Right-side discharge	Dual-PRO Super Wheels	Yes
		Blue Diamond Liner	Yes