

APPLICATION AND USE:

The Cyclone Rake Classic is smaller and more maneuverable than the Cyclone Rake Commander, Cyclone Rake Commercial PRO or the Cyclone Rake XL. Because of smaller size, it weighs less when full. It is particularly advantageous under three conditions:

1. Properties which are tightly congested due to fences, closely spaced plantings, smaller lawn areas and closely spaced trees. Also, properties with limited turning space.
2. Owners of smaller riding mowers, especially rear-engine riders and front engine mowers of less than 10 horsepower.
3. Properties having steep slopes and lawn gradients. The smaller size and weight gives better steering control on steep slopes, and less strain on the mower.

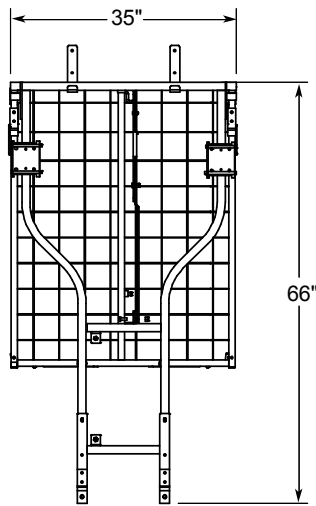

As folded flat, for wall mounting.

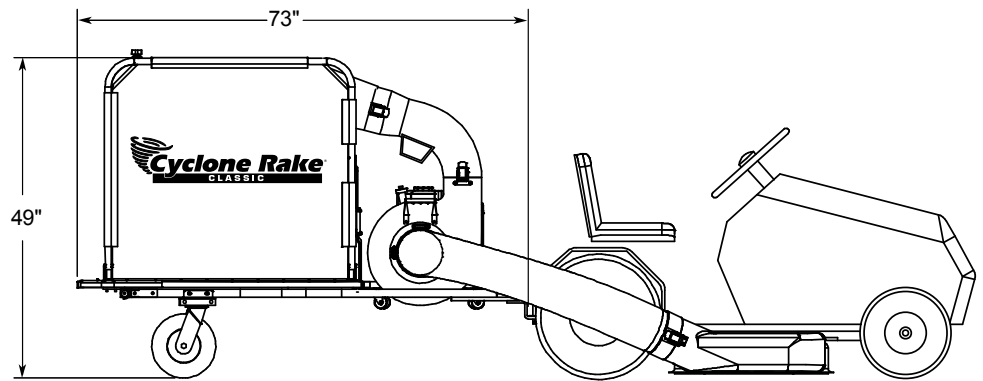

Side elevation view

Product Specifications

Capacity	200 gal. • 27 cu. ft. • 22 bushels
W x H x L	35" x 49" x 73"
Engine	5.5 HP OHV B&S Vanguard 8.5 ft.lbs. of torque
Vacuum system	Standard
Mower deck hose	7-inch diameter
Miracle Impeller	4-blade heavy duty
Easy-Flow™ unloading	Standard
Collector dumping angle	60°
Rigid dumping lock	Yes
Hitch type	never jackknives
Folds flat for storage	Yes

Mower or Tractor Requirements

Mower or tractor required	8 HP or larger. Rear engine, front engine or ZTR.
Mower deck requirement	Right-side discharge

Accessories Available

32 ft. Estate Vacuum	(1)
17 ft. Power Vacuum Pickup	Yes
Power Bagger	Yes
Roof Rack Carrier	Yes
Power Unloader	Yes
Wall Mount Kit	Yes
3rd Wheel Jack Stand	Yes
Mower Deck Adapter (MDA)	Yes
Cyclone Master Power Lifter	Yes
Cyclone Mate Power Lifter	Yes
Weather Defender Outdoor Cover	Yes

PRO Upgrades Available

Tuff-PRO Super Hose	Yes
Dual-PRO Super Wheels	Yes
Blue Diamond Liner	Yes

(1) Recommended for use with Commander, Commercial PRO or XL models.

WOODLAND POWER PRODUCTS, INC.

72 Acton Street, West Haven, Connecticut 06516

www.CycloneRake.com

©2009, Woodland Power Products, Inc.

TOLL-FREE 1-(888)-531-RAKE

01-06-072 F09